

**KETEK**

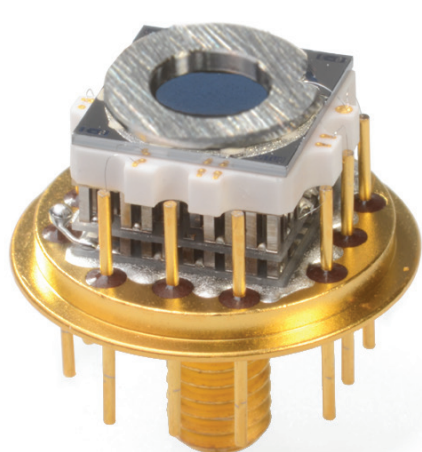

**VITUS H20LE**  
30 mm<sup>2</sup> collimated  
to 20 mm<sup>2</sup>

**H20LE  
VITUS**

### X-ray Silicon Drift Detector

- Ultra-low-capacitance ASIC (CUBE) as first amplification stage
- Excellent energy resolution at very short peaking times down to 0.1 μs
- Sensitive down to Boron Kα at 185 eV
- Very high count rate capability up to 2 Mcps
- Operable at up to +50 °C heat sink temperature with outstanding performance
- Best in class peak to background > 10,000 typ.
- Very short signal rise times
- High cooling performance of built-in TEC
- Fully RoHS compatible

#### Guaranteed Specifications

First stage amplification	ASIC
Energy resolution	≤ 129 eV
Peak to background	> 10,000
Peak to tail	> 2,000
Optimal peaking time at max. cooling	1 μs
Absorption depth Si	450 μm
Peak shift stability up to 100 kcps	< 1 eV
Max. input count rate	2,000 kcps
Window	AP3.3 polymer
Cooling performance	ΔT > 65 K
On-chip collimator	Pd

Ordering code **V000-C7T0-H020-PD3E**

#### Typical spectrum with VITUS H20LE-CUBE

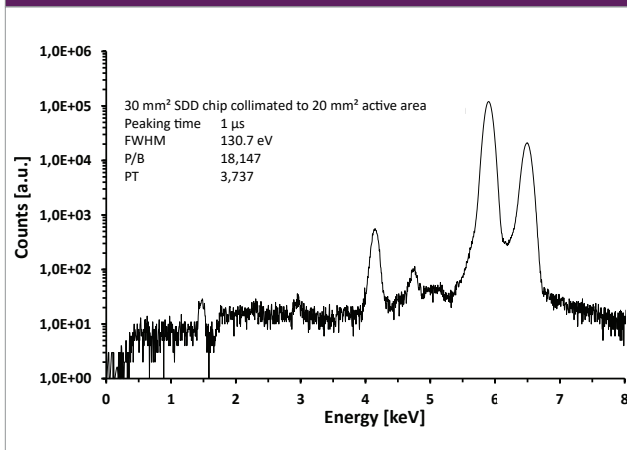

#### FWHM vs. Peaking Time at different chip temperatures

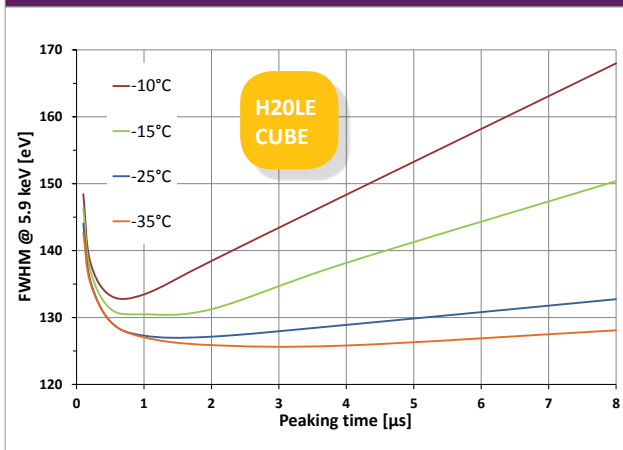

**KETEK GmbH**

Hofer Str. 3  
81737 Munich, Germany

www.ketek.net  
info@ketek.net

phone +49 89 673 467 70  
fax +49 89 673 467 77

Rev. 2018-06



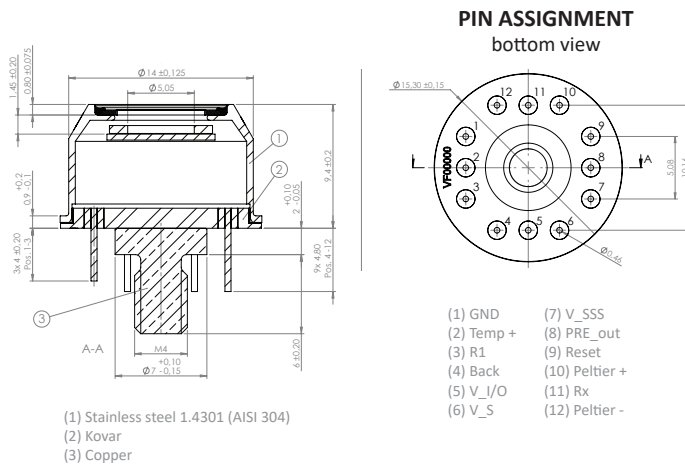

Typical SDD parameters	Voltages	Currents
Ring 1 (R1)	-20 V ± 5 V	10 µA
Ring X (RX)	-130 V ± 20 V	10 µA
Back	-60 V ± 5 V	<1 nA
Peltier element (low energy window)	4.0 V	1000 mA max.
Temperature monitor	NTC thermistor 10 kΩ @ 25 °C *(application note with linearization circuit available)	
Output signal	ramped reset type	
Output gain	1.6 mV/keV ± 20 %	

Product	Description
<p><b>VIAMP SDD PLUS PREAMPLIFIER MODULE</b></p>	<p>The <b>VITUS Amplifier</b> is a combination of a VITUS SDD and a low-noise preamplifier circuit, encapsulated in a compact aluminum housing, functioning as an appropriate heat sink. A standardized FFC flex cable connector is integrated. Customized versions for your individual application are also available on request. The VIAMP module can be equipped with all VITUS SDDs from H7 to H50.</p>
<p><b>AXAS-A ANALOG SDD SYSTEM</b></p>	<p>The <b>AXAS-A</b> is an <u>analogue</u>, vacuum-compatible spectroscopic detector system with regulated power supplies, TEC controller and low-noise preamplifier. This detector system can be equipped with all VITUS SDDs from H7 to H50. The standard finger length is 100 mm, other lengths from 35 to 200 mm are available on request.</p>
<p><b>AXAS-D DIGITAL SDD SYSTEM</b></p>	<p>The <b>AXAS-D</b> is a completely <u>digital</u>, vacuum-compatible spectroscopic detector system. The AXAS-D consists of regulated power supplies, TEC controller, low-noise preamplifier and features, in addition to the AXAS-A, the KETEK digital pulse processor DPP2. This detector system can be equipped with all VITUS SDDs from H7 to H50. The standard finger length is 100 mm, other lengths from 35 to 200 mm are available on request.</p>
<p><b>EMLCOL CLIP-ON MULTILAYER COLLIMATOR</b></p>	<p>For all VITUS SDDs up to the H50 a specially designed clip-on protection cap is available. It provides an additional external multilayer collimator to prevent the SDD cap's material excitation (stainless steel). In addition, it further improves P/B and P/T of the detector by preventing the undershooting of the internal multilayer collimator (setup geometry dependent). The EMLCOL also provides an additional protection of the VITUS entrance window.</p>