

KETEK

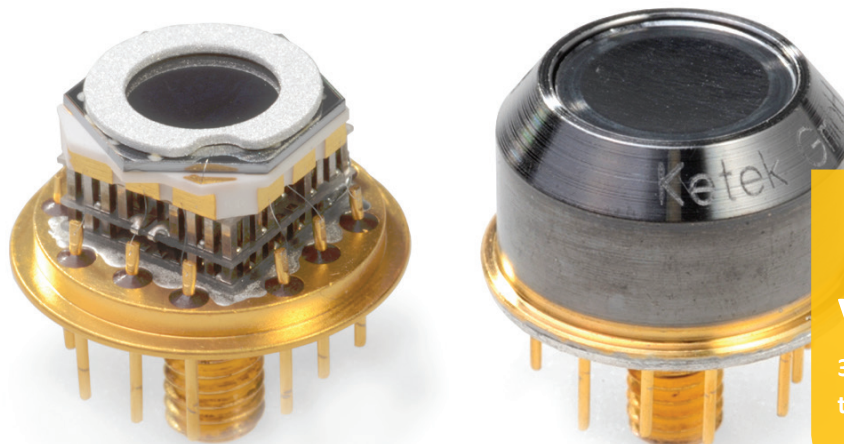

VITUS H20
30 mm² collimated
to 20 mm²

**H20
VITUS**

X-ray Silicon Drift Detector

- Ultra-low-capacitance ASIC (CUBE) as first amplification stage
- Excellent energy resolution at very short peaking times down to 0.1 μs
- Very high count rate capability up to 2 Mcps
- Operable at up to +50 °C heat sink temperature with outstanding performance
- Best in class peak to background > 20,000 typ.
- Very short signal rise times
- High cooling performance of built-in TEC
- Fully RoHS compatible

Guaranteed Specifications

First stage amplification	ASIC
Energy resolution	≤ 129 eV
Peak to background	> 15,000
Peak to tail	> 2,000
Optimal peaking time at max. cooling	1 μs
Absorption depth Si	450 μm
Peak shift stability up to 100 kcps	< 1 eV
Max. input count rate	2,000 kcps
Window Be DuraCoat Plus	8 μm
Cooling performance	ΔT > 75 K
On-chip collimator	multilayer

Ordering code **V5C2T0-H20-ML1BEV**

Typical spectrum with VITUS H20-CUBE

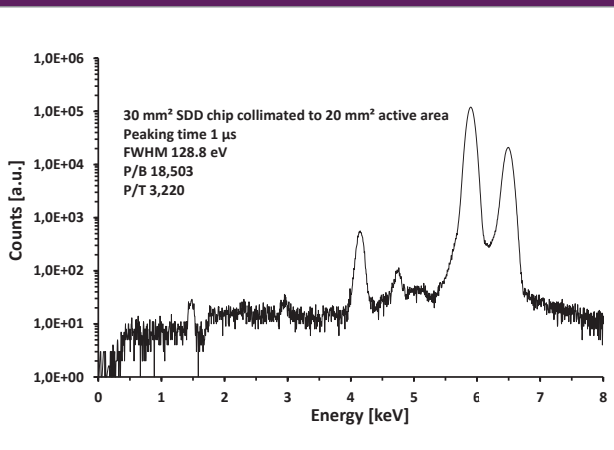

FWHM vs. Peaking Time at different chip temperatures

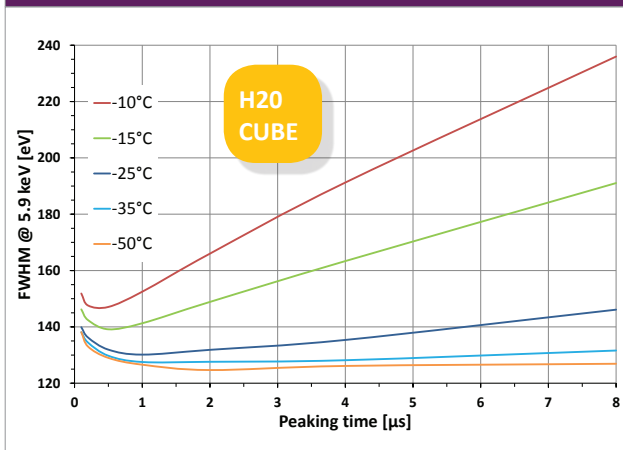

KETEK GmbH

Hofer Str. 3
81737 Munich, Germany

www.ketek.net
info@ketek.net

phone +49 89 673 467 70
fax +49 89 673 467 77

Rev. 2018-06



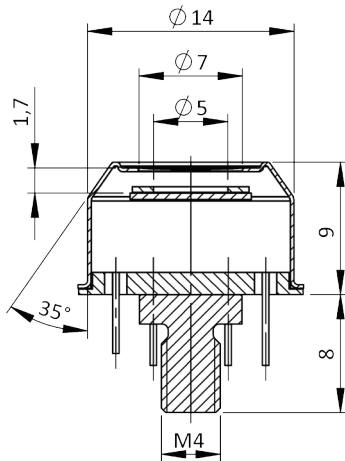

PIN ASSIGNMENT
bottom view

Peltier- RX Peltier+

Temp-/GND
Temp+
R1

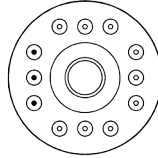

Reset
PRE_OUT
V_SSS

Back V_I/O V_S

● Short Pins

Typical SDD parameters	Voltages	Currents
Ring 1 (R1)	-20 V ± 5 V	10 µA
Ring X (RX)	-130 V ± 20 V	10 µA
Back	-60 V ± 5 V	<1 nA
Peltier element (Be window)	3.6 V	700 mA max.
Temperature monitor	NTC thermistor 10 kΩ @ 25 °C *(application note with linearization circuit available)	
Output signal	ramped reset type	
Output gain	1.6 mV/keV ± 20 %	

Product	Description
<p>VIAMP SDD PLUS PREAMPLIFIER MODULE</p>	<p>The VITUS Amplifier is a combination of a VITUS SDD and a low-noise preamplifier circuit, encapsulated in a compact aluminum housing, functioning as an appropriate heat sink. A standardized FFC flex cable connector is integrated. Customized versions for your individual application are also available on request. The VIAMP module can be equipped with all VITUS SDDs from H7 to H50.</p>
<p>AXAS-A ANALOG SDD SYSTEM</p>	<p>The AXAS-A is an <u>analogue</u>, vacuum-compatible spectroscopic detector system with regulated power supplies, TEC controller and low-noise preamplifier. This detector system can be equipped with all VITUS SDDs from H7 to H50. The standard finger length is 100 mm, other lengths from 35 to 200 mm are available on request.</p>
<p>AXAS-D DIGITAL SDD SYSTEM</p>	<p>The AXAS-D is a completely <u>digital</u>, vacuum-compatible spectroscopic detector system. The AXAS-D consists of regulated power supplies, TEC controller, low-noise preamplifier and features, in addition to the AXAS-A, the KETEK digital pulse processor DPP2. This detector system can be equipped with all VITUS SDDs from H7 to H50. The standard finger length is 100 mm, other lengths from 35 to 200 mm are available on request.</p>
<p>EMLCOL CLIP-ON MULTILAYER COLLIMATOR</p>	<p>For all VITUS SDDs up to the H50 a specially designed clip-on protection cap is available. It provides an additional external multilayer collimator to prevent the SDD cap's material excitation (Nickel). In addition, it further improves P/B and P/T of the detector by preventing the undershooting of the internal multilayer collimator (setup geometry dependent). The EMLCOL also provides an additional protection of the VITUS entrance window.</p>