

KETEK

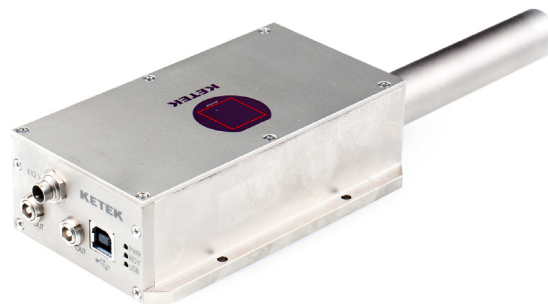
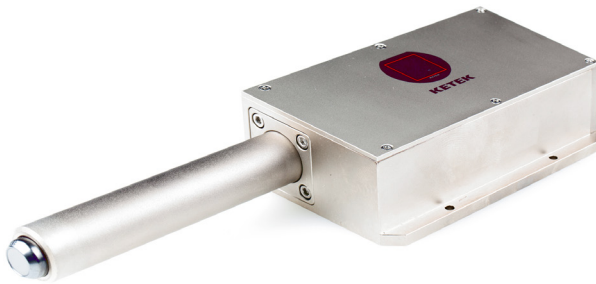

AXAS-D
digital

D
AXAS

Analytical X-Ray Acquisition System - Digital

- Highly integrated design with all power options
- All VITUS SDD types (FET and CUBE) from 7 mm to 50 mm² available
- KETEK reset-type pre-amplifier
- Low-noise power supplies for SDD and TEC
- SDD operating temperature read-out
- Finger lengths from 50 to 200 mm
- Vacuum compatible
- High-speed USB 2.0 and RS-232 interfaces

FWHM vs. ICR for AXAS-D with H2O-CUBE at -35 °C

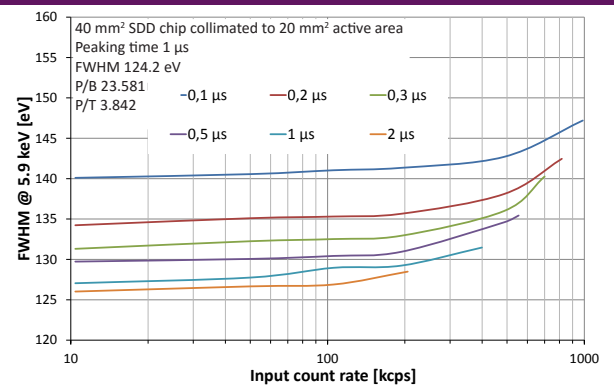

Typical spectrum of H2O-CUBE in AXAS-D

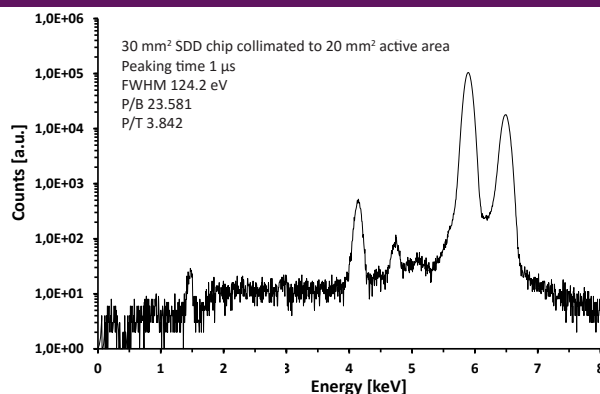

FWHM vs. chip temperature for AXAS-D with H2O-CUBE

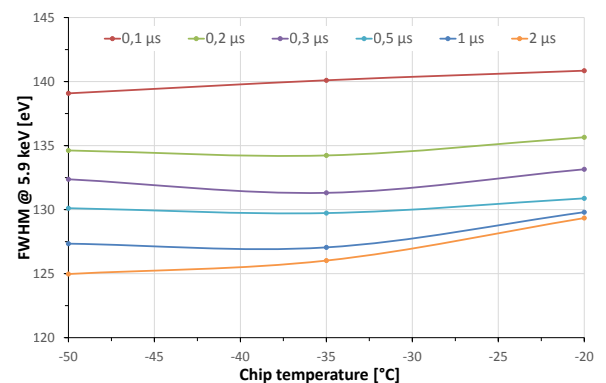

KETEK GmbH

Hofer Str. 3
81737 Munich, Germany

www.ketek.net
info@ketek.net

phone +49 89 673 467 70
fax +49 89 673 467 77

Rev. 2017-04



AXAS-D front and back view

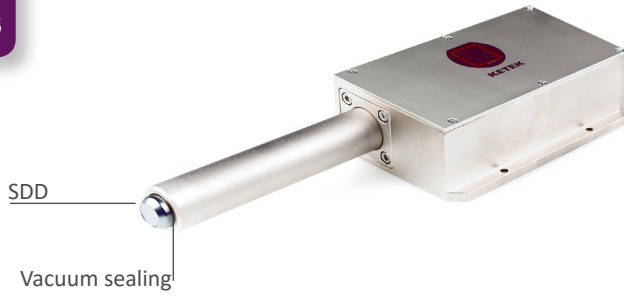

FRONT

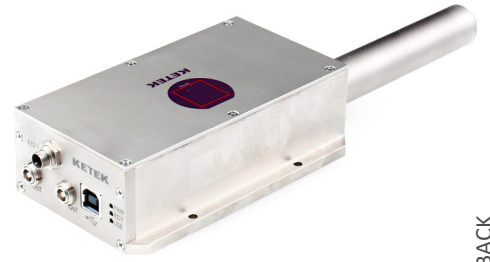

BACK

AXAS-D housing geometry in mm [inch]

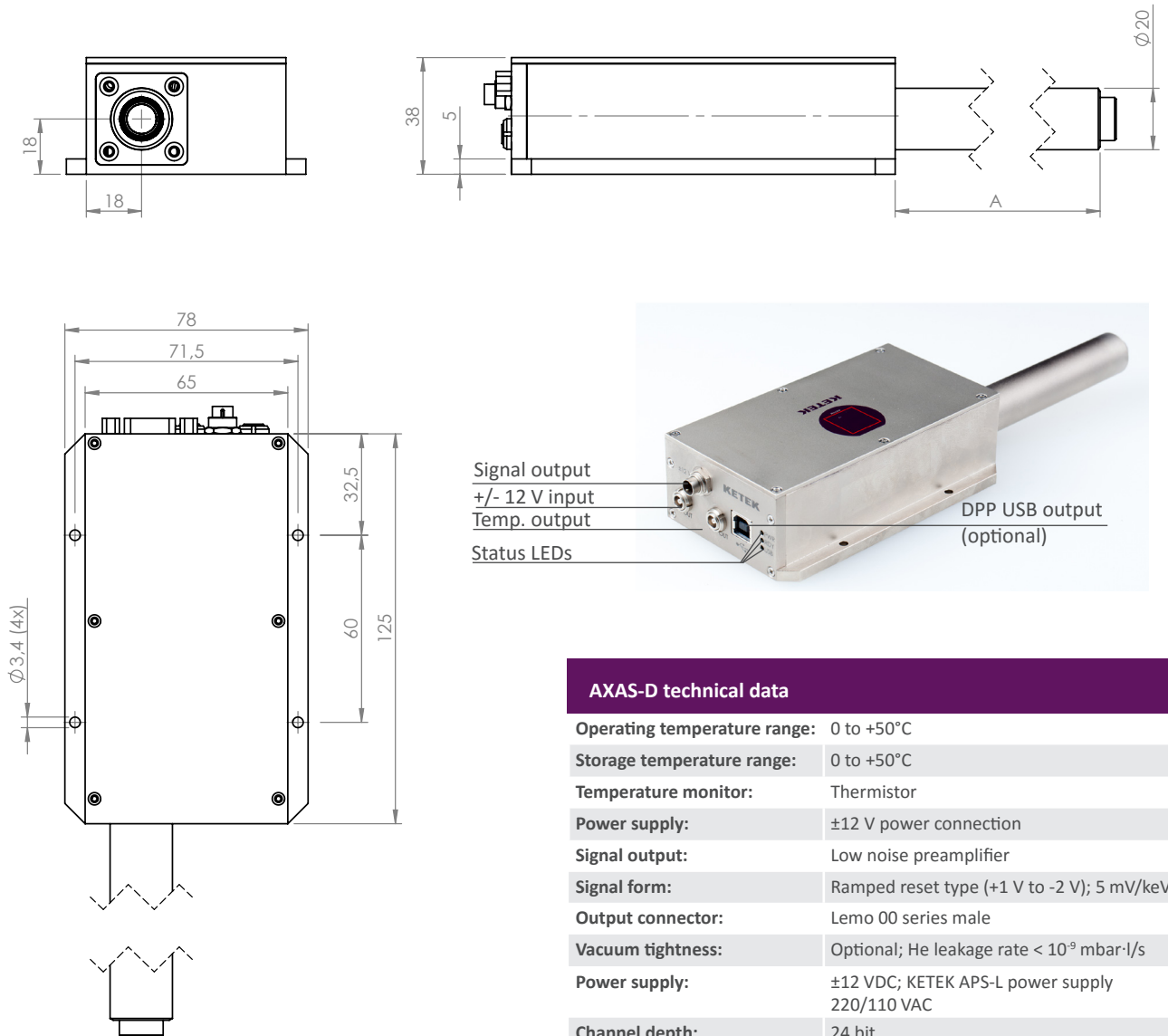

AXAS-D options

DPP with USB 2.0 MS-Windows acquisition software available

VITUS SDD H7, H7LE, H18LE, H20, H30 and H50

Finger length [mm] Std: 100, 50, 160 and 200 on request.

AXAS-D technical data

Operating temperature range:	0 to +50°C
Storage temperature range:	0 to +50°C
Temperature monitor:	Thermistor
Power supply:	±12 V power connection
Signal output:	Low noise preamplifier
Signal form:	Ramped reset type (+1 V to -2 V); 5 mV/keV
Output connector:	Lemo 00 series male
Vacuum tightness:	Optional; He leakage rate < 10 ⁻⁹ mbar·l/s
Power supply:	±12 VDC; KETEK APS-L power supply 220/110 VAC
Channel depth:	24 bit
Number of channels:	max. 8192
ADC:	14 bit
Peaking rtime range:	0.1 to 24 µs in 24 steps
Maximum read-out speed:	1 ms (@1024 channels)
Software parameters :	Digital gain, threshold, peaking time
Clock frequency:	40 MHz